

EUROVAC

TEL: 1-800-265-3878

www.eurovac.com

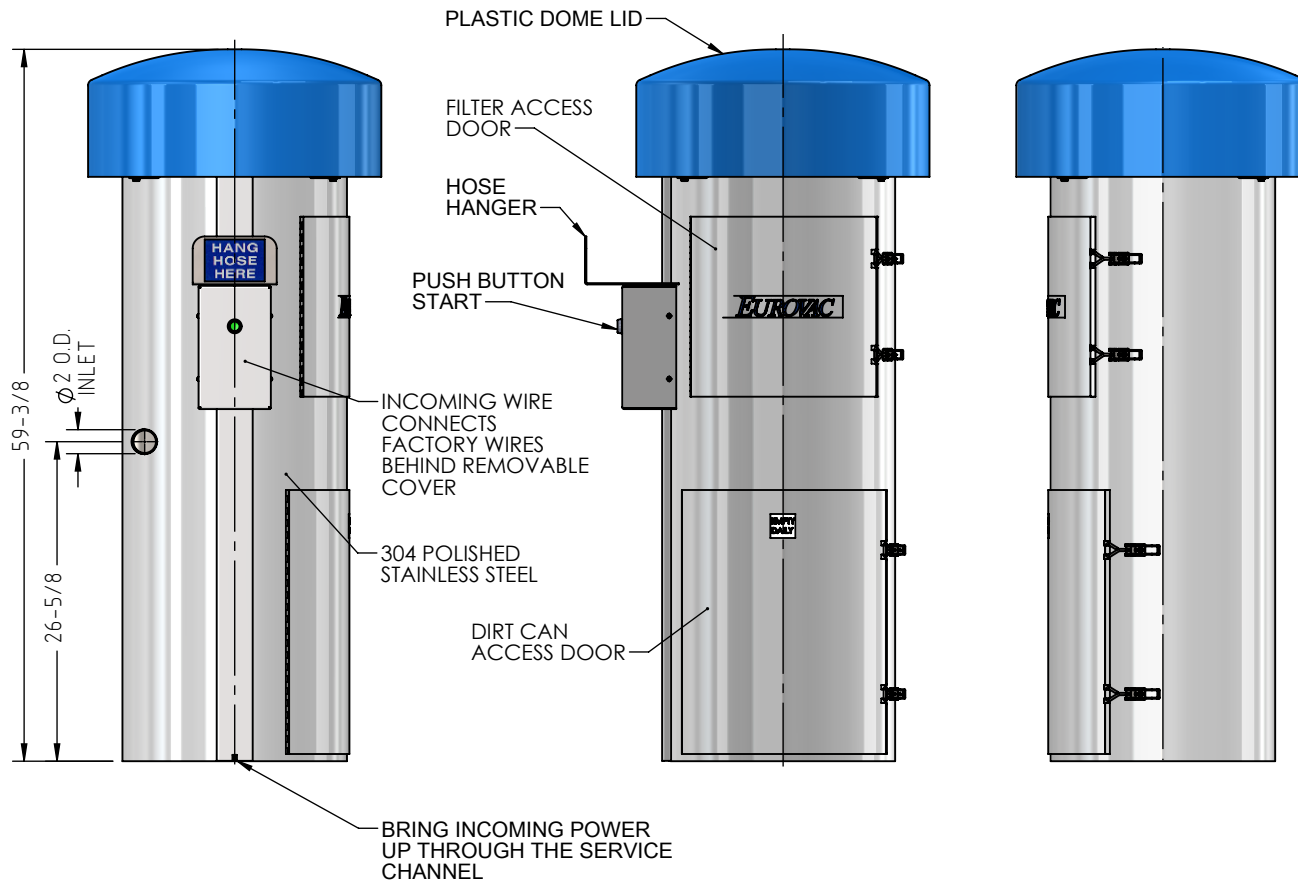
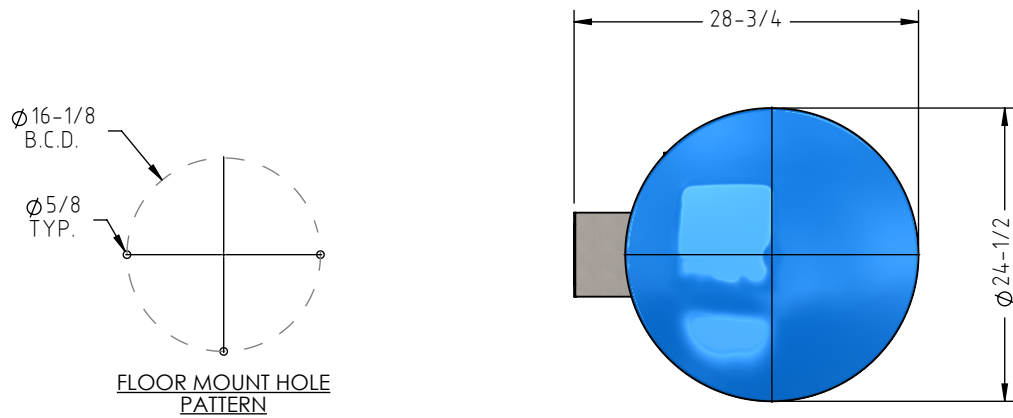

GENERAL TABLE		
1	1.6 HP BRUSH MOTOR (X2)	SYS-050-11700000
	MOTOR VOLTAGE: SINGLE PHASE 115/1/60	
2	MOTOR F.L. AMPS: 20	
	18" S.S. FILTER SEPARATOR	-
	5-3/4" x 16" BAG FILTER	FIL-057-16VP1011
	NUMBER OF FILTER/AREA - 4/12 SQ. FT.	
	$\varnothing 12"$ 23L POLYETHYLENE PLASTIC PAIL	HAR-AVE-A3218000
SOUND LEVEL		70 dBA
TOTAL WEIGHT: 140 LBS		

INLET OPTIONS:
 1 - 2" INLET

REVISIONS		
REV.NO.	DESCRIPTION	DATE

EII S.S. 2 MOTORS STAND ALONE SYSTEM

DRAWN BY: J.C.	SCALE: 1:16
CHECKED BY: C.B.	DATE: 11/25/24
DWG. NO.: BS 18SS-00	
PART NO.: POR-S32-BL10S2PC	

THIS DOCUMENT CONTAINS PROPRIETARY AND
 CONFIDENTIAL DATA OF EUROVAC. NO DISCLOSURE
 REPRODUCTION OR USE OF ANY PART THEREOF,
 MAY BE MADE WITHOUT WRITTEN PERMISSION OF
 THE COMPANY.